

Pick & Place Robot YF003N

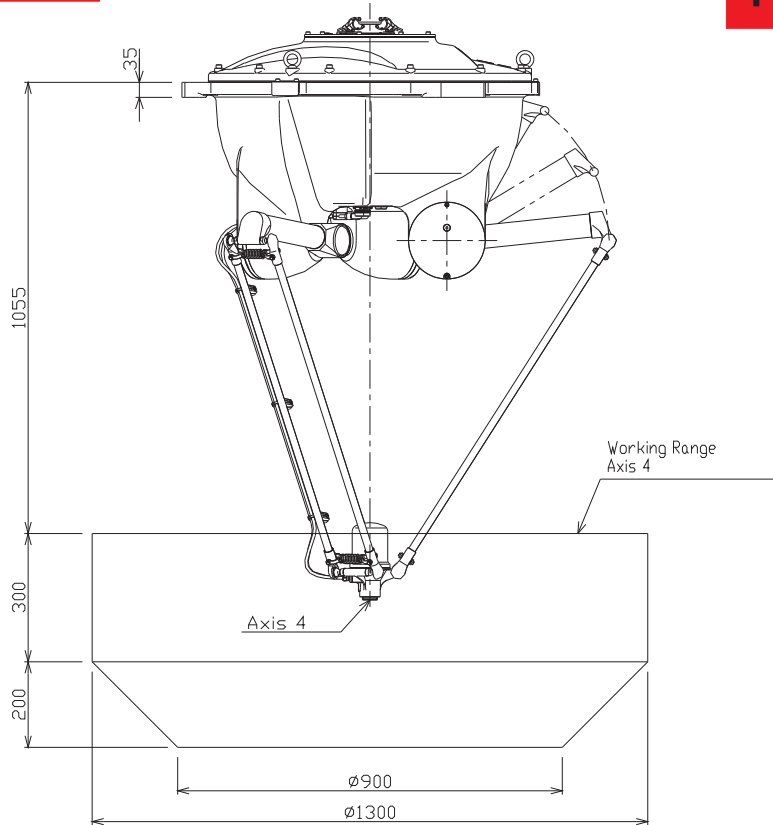

- high Repeatability
- high Speed



Specifications

Axis	Working Range (max.)	Speed (max.)
1	+95°~-54°	1090,9°/s
2	+95°~-54°	1090,9°/s
3	+95°~-54°	1090,9°/s
4	+360°~-360°	1714,3°/s
Payload (max.)	3 kg	
Repeatability	± 0,10mm / ± 0,10°	
cycle time [sec.]	0,27 (1kg) / 0,45 (3kg)	
Mass	135kg (without options)	
Mounting Position	Ceiling	
Option	5th axis	

Axis	Moment (max.)
4	10 Nm
Achse	Torque (max.)
4	7 Nm

environment

Rel. Humidity	35 – 85 %
Temperature	0 – 45 °C

Controller: E40

Power Requirement	3 Phasen; 50/60Hz; 4,9kVA; 400VAC±10%
Mass	145kg
Dimensions	550 x 550 x 1.200 mm (W x D x H)

Technical Specifications and external appearance are subject to change without prior notice.



Headquarter

Sperberweg 29, 41468 Neuss
E-mail: info@kawasakirobot.de
Tel: +49 (0)2131-3426-0
Fax: +49 (0)2131-3426-22

Office Munich

Tel: +49 (0)89-454591-30
Fax: +49 (0)89-454591-45

Office Osnabrück

Tel: +49 (0)541-4069398-0
Fax: +49 (0)541-4069398-11